

AKU230

CMOS MEMS Digital Microphone

www.akustica.com

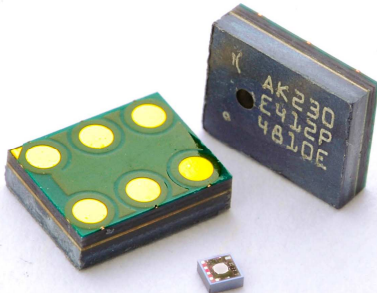

General Description

The AKU230, Akustica's 4th generation of CMOS MEMS microphone, is a top ported, surface mountable, digital output microphone which can be used in any design that currently uses a 3.76mm x 4.72mm digital microphone footprint. Akustica's digital microphones are the world's first and only surface-mountable monolithic digital MEMS microphones that integrate an acoustic transducer, pre-amplifier, and sigma-delta modulator in a single chip of silicon that is only 0.7mm².

The robust digital output stream from the AKU230 is virtually immune to all forms of Radio Frequency Interference (RFI) and Electromagnetic Interference (EMI) allowing the microphone to be integrated anywhere on the platform regardless of proximity to displays, Wi-Fi antennae, or other sources of interference that would degrade the signal of conventional analog microphones. For the manufacturer, this translates to the highest degree of design flexibility and freedom, and ultimately faster time-to-market.

The output of the microphone is pulse density modulation (PDM), a single-bit digital output stream which enables the multiplexing of stereo microphone data onto a single wire. With a user selectable L/R channel option, the AKU230 is ideal for use in multiple microphone applications such as microphone arrays mounted on embedded camera modules in laptop PCs.

Key Features

- ▶ High performance, omni-directional digital microphone with PDM (Pulse Density Modulated) output
- ▶ Industry-standard form, fit, and function for easy integration into existing designs
- ▶ 3.76 x 4.72 x 1.25mm³ form factor
- ▶ World's smallest fully integrated microphone die measures 0.7mm²
- ▶ Robust digital-output immune to RF/EM interference
- ▶ Highly-matched microphones in frequency and phase response for array applications
- ▶ Sensitivity of -26dBFS
- ▶ Ultra-low power sleep current
- ▶ Pb-free and RoHS compliant
- ▶ Halogen Free in accordance with IEC61249-2-21

Target Applications

- ▶ Laptop computers and tablet PCs designed to support high quality voice applications and where a high degree of EM/RF immunity is required
- ▶ Microphone arrays where noise cancellation and beam steering applications can be optimized by using closely-matched microphones in phase and sensitivity.
- ▶ Other small, thin consumer electronic devices using more than one microphone

Functional Block Diagram

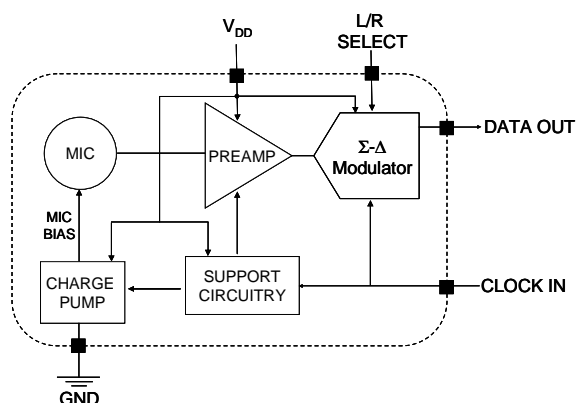

Technical Specifications	
Operating voltage	2.3V to 3.6V
Directivity	Omnidirectional
SNR	56dB
Power Supply Rejection	-57dBFS
Sensitivity	-26dBFS
Frequency Range	50Hz to 22KHz
Current Consumption (with no load, typ.)	11uA (clock off)
Power up Initialization	20ms (max)
Port Location	Top
Package Dimensions	3.76 x 4.72 x 1.25mm ³

Akustica Advantages

The AKU230 leverages Akustica's patented monolithic complementary metal-oxide semiconductor (CMOS) MEMS platform, a technology which integrates the mechanical function of microphones and other sensors with analog and digital electronics—all in a single chip. Unlike other MEMS microphone manufacturers who may buy any or all of their MEMS, ASIC, and package design from a third party, Akustica has always maintained complete in-house MEMS, ASIC, and packaging design teams.

Akustica's audio expertise and design services are unparalleled in the digital microphone market. In addition to providing world class digital MEMS microphones, Akustica offers acoustic design, testing and certification services for our customers and partners. Akustica has performed extensive testing using CODECS from the industry's leading vendors to guarantee our customers a seamless integration experience. Akustica offers acoustic design review and modelling services to help save system design time prior to assembly. Akustica also provides production test services, training, and test equipment to help ensure the quality of both incoming and final assembled products.

Ordering information

Part Number	AKU230R
Description	Digital MEMS Microphone
Package	6 Pad LGA
Shipping Method	13" Reel
Standard Quantity	4800

Typical Frequency Response

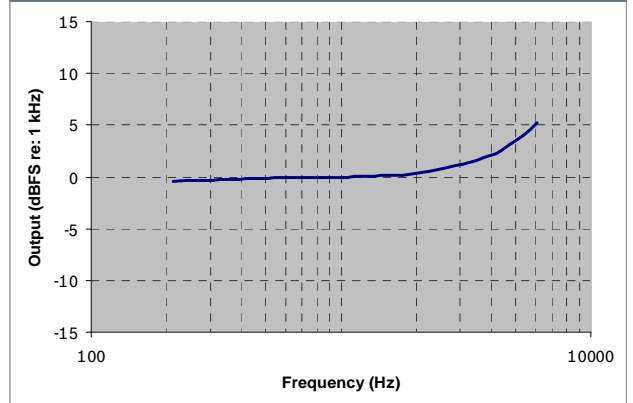

About Akustica – Bosch Group

Akustica was founded in 2001 to develop and market a complete portfolio of digital and analog microphones using the unique and patented CMOS MEMS technology developed at Carnegie Mellon University. In 2009, Akustica was acquired by, and is now a wholly owned subsidiary of, Robert Bosch North America. As part of the Bosch Group, Akustica joins a family of companies with combined annual sales approaching \$65 billion and a footprint of 283,500 associates worldwide.

Bosch has been active in the field of MEMS since 1988 and is one of the pioneers in microsystem-technology. Bosch serves both the automotive and consumer electronics markets with a wide variety of MEMS products, including pressure sensors, accelerometers and gyroscopes. With more than 1.6 billion MEMS sensors shipped worldwide since 1993, Bosch is the world's leading supplier of MEMS sensors.

Please contact Akustica for further information.

Akustica, Inc.

2835 East Carson Street, Suite 301
 Pittsburgh, PA 15203 USA
 sales: sales@akustica.com
 ph: (412) 390-1730 fx: (412) 390-1737
www.akustica.com