

# AKU230

## Microphone Module Design Guide



### Application Note – Microphone Module Design Guide

Part number(s)	AKU230
Package type	6-pin LGA top port
Application Note revision	1.0
Release date	29 April 2011
Document number	AN44-1.0

Notes

Specifications are subject to change without notice.  
Product photos and pictures are for illustration purposes only and may differ from the real product's appearance. For additional information, contact Akustica marketing (AKUS/MKT).

## AKU230 Microphone Module Design Guide

This document provides complete mechanical and electrical guidelines for the design of an embedded microphone module (with or without cameras), as shown in Figure 1, that will be used in laptop PC's, monitors, tablets or other module applications. All electromechanical recommendations in this guide will also apply to any design using the AKU230 digital MEMS microphone and can be applied to any form factor. The first two sections discuss the types of embedded microphone modules and the recommended location for the module. The last two sections present electrical layout guidelines and mechanical/plastics recommendations for optimum acoustic performance and ESD protection of the microphone module.

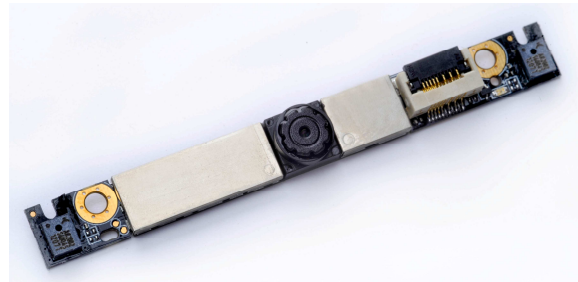

**Figure 1:** Audio/video module with dual digital microphones

A quick summary of the electrical and mechanical guidelines for designing the highest quality audio module is shown in Table 1. All recommendations are covered in greater detail on the page number indicated.

Microphone Module Location	<ul style="list-style-type: none"> <li>• Top of the display bezel in the laptop PC or desktop monitor.</li> </ul>
Electrical Design Recommendations for Motherboard Manufacturer	<ul style="list-style-type: none"> <li>• A series resistor of 100Ω-250Ω or higher should be placed on the CLK line close to the codec output on the motherboard to terminate the clock line to prevent clock overshoot and ringing.</li> </ul>
Electrical Design Recommendations for Microphone Module Manufacturer	<ul style="list-style-type: none"> <li>• A 0.1 μF decoupling capacitor should be placed between <math>V_{DD}</math> and GND as close to the microphone as possible (for each microphone on the module) in order to suppress high frequency transients and decrease susceptibility to ESD events.</li> <li>• If CLK line has not been terminated on the motherboard, a larger series resistor of 200Ω-600Ω or higher must be placed on the CLK line of the module to prevent clock overshoot and ringing as seen by the part.</li> <li>• GND line should be routed next to CLK line.</li> </ul>
Mechanical Design Recommendations	<ul style="list-style-type: none"> <li>• The design of the acoustic port should minimize port height (H) and maximize port diameter (D), while maintaining an airtight seal between the acoustic port of product's housing and the microphone.</li> </ul>

**Table 1:** Summary of design recommendations for integrated camera modules in laptops

	<b>AKU230</b> Microphone Module Design Guide	Application Note
-----------------------------------------------------------------------------------	-------------------------------------------------	------------------

## Index of Contents

<b>1. INTEGRATED MICROPHONE MODULE TYPES .....</b>	<b>4-5</b>
<b>2. MICROPHONE MODULE LOCATION.....</b>	<b>6</b>
<b>3. ELECTRICAL DESIGN .....</b>	<b>7-9</b>
3.1 Clock Signal Recommendations	
3.2 Reference Module Schematics	
<b>4. ACOUSTIC DESIGN .....</b>	<b>10-11</b>
4.1 Gasket Design	
4.2 Acoustic Port Design	
4.3 Mechanical Design	
<b>5. DEVICE HANDLING .....</b>	<b>12-13</b>
5.1 ESD	
5.2 Pick and Place Tools	
<b>6. CONCLUSION.....</b>	<b>13</b>

	<b>AKU230</b> Microphone Module Design Guide	Application Note
-----------------------------------------------------------------------------------	-------------------------------------------------	------------------

## 1. TYPES OF INTEGRATED MICROPHONE MODULES

There are three main types of microphone modules for laptop PCs and desktop monitors:

- Camera modules with microphones which output audio data to the HD Audio codec on the motherboard. This is the type most likely to be used in a laptop PC.
- Camera module with microphones which output audio data to an on-board audio/video controller which ultimately outputs USB audio and video. This is the type most likely to be used in a desktop monitor or external webcam.
- Microphone-only module which outputs audio data to the HD Audio codec (or other digital mic capable codec) on the motherboard. This is the type most likely to be used in tablet or low-cost applications.

In the first type of the module, either the mono or the stereo (multiplexed) single-bitstream output of the AKU230 microphone(s) is routed directly from the module to the HD Audio codec that is located on the motherboard of the laptop. Because the output of the AKU230 is digital and therefore has a high degree of immunity to RFI/EMI (radio frequency and electromagnetic interference), it is not necessary to use shielded cabling when routing this signal down the side of the bezel, through the hinge, and to the motherboard.

These modules also often include a camera whose output goes directly into the video controller located on the module which generates video in USB format. The block diagram of this type of microphone module is shown in Figure 2.

In this implementation, the video output of the camera module is in the USB format, while the audio output of the camera module is the multiplexed single bitstream output from the microphones.

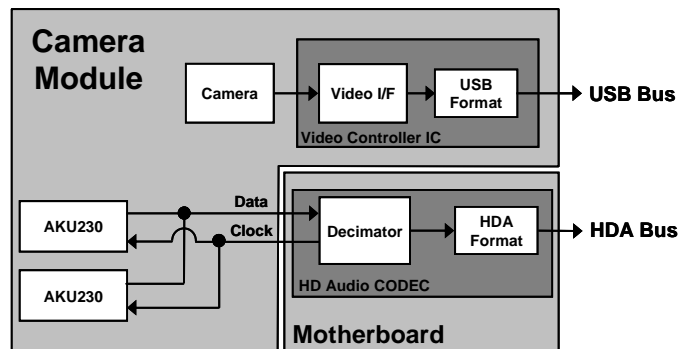

**Figure 2:** Camera module with HDA-based digital microphone array and USB video controller.

	<b>AKU230</b> Microphone Module Design Guide	Application Note
-----------------------------------------------------------------------------------	-------------------------------------------------	------------------

The second type of microphone module is shown in Figure 3. In this implementation, the module also includes a camera and the on-module audio/video controller has been designed to directly interface with digital microphones. In this case, both the audio and the video output from the camera module are in USB format. This camera module solution is the most simple to integrate as it has the least number of wires running from the camera module, through the hinge, and to the motherboard.

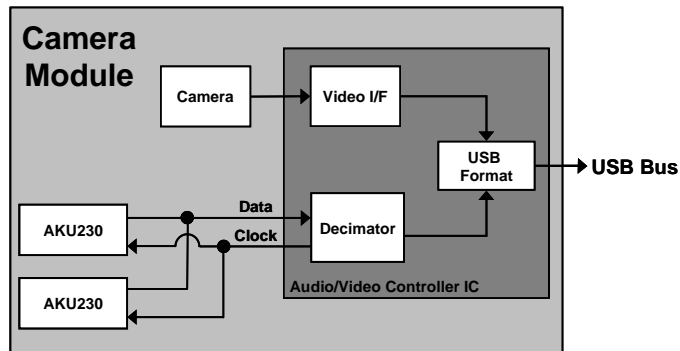

**Figure 3:** Camera module with digital microphone array and USB audio/video controller

Figure 4 shows a third type of microphone module which eliminates the camera and Audio/Video Controller IC. This type of module is often used in cost-down platforms with reduced feature sets to save on cost or also can be used when space is a limiting factor and/or the thickness of the camera sensor interferes with the industrial design of the product. For advanced space-efficient designs, mic-only modules can be made using flex cable rather than standard FR4 to additionally reduce the module size as well as increase cable routing options.

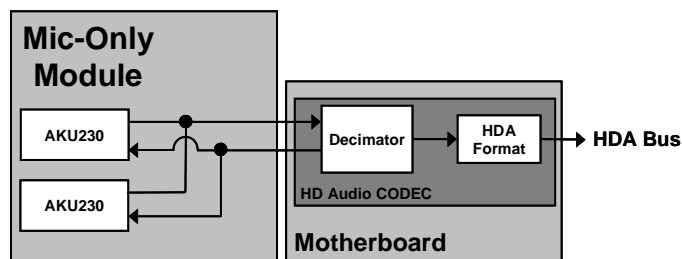

**Figure 4:** Mic-only module with HDA-based digital microphone array.

For any microphone module using two or more microphones, the spacing of the microphones will be determined by the particular microphone array software used in the platform since these algorithms are typically optimized for specific distances between microphones in the array. Beam forming software from Andrea Electronics (<http://www.andreaelectronics.com/>) is often included in laptops and it is also recommended that designers follow the guidelines outlined in the Microsoft white paper entitled “Microphone Array Support in Windows Vista” which can be found at <http://www.microsoft.com/whdc/device/audio/micarrays.mspx>.

	<b>AKU230</b> Microphone Module Design Guide	Application Note
-----------------------------------------------------------------------------------	-------------------------------------------------	------------------

## 2. MICROPHONE MODULE LOCATION

The typical location for a camera module is in the top of the display bezel in the laptop PC. The following section discusses why this is also the ideal location for a microphone array and therefore also for the integrated audio/video camera module.

The positioning of an integrated microphone array should be selected both to maximize the audio signal and to minimize external noise experienced at the microphone, thereby improving the overall SNR (signal-to-noise ratio). It is recommended that to maximize the SNR of the audio signal and take full advantage of the microphone array signal processing, microphones should be embedded in the display bezel, facing the talker. This provides the most direct path from mouth to microphone, enabling optimum talker tracking and ambient noise suppression.

To minimize mechanical noise interference on the microphone array, place the microphones as far as possible from internal laptop noise sources such as the fan, speaker, and keyboard which are typically located in the laptop base. The sound pressure level reaching the microphones from each of these sound sources will be reduced by 6 dB when the distance between the microphone and the noise source is doubled. Therefore, minimal noise interference will be experienced by the array if it is removed from the base and is placed at the farthest possible point away from noise sources.

Consequently, one can both increase signal and decrease internal laptop noise by placing the microphone array (or the integrated audio/video camera module) in the top bezel of the laptop display as shown in Figure 5.

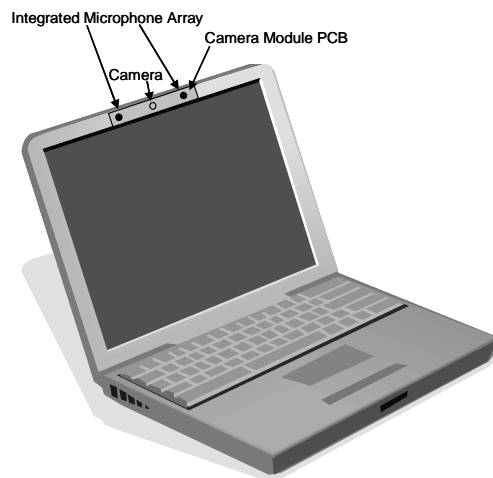

**Figure 5:** Ideal location for camera module with integrated microphone array

	<b>AKU230</b> Microphone Module Design Guide	Application Note
-----------------------------------------------------------------------------------	-------------------------------------------------	------------------

### 3. ELECTRICAL DESIGN

There are several options for integrating the surface-mountable AKU230 into the bezel of a notebook PC. One solution is to surface-mount the microphones individually to small boards in the bezel and connect a 4-wire harness (power, ground, clock, and data) to each microphone. If taking advantage of the multiplexing capabilities of the AKU230, the data lines can then be tied together as they are routed to the codec. Alternatively, the microphones can be directly mounted to a board that already exists in the display bezel such as those with internal camera modules.

Another solution is to use a thin flex cable extending from the microphone to the codec. The flex cable is convenient in that it is easy to design very thin; however, flex cables may not provide the most cost-effective solution for mounting a microphone array in a laptop. Since the AKU230 signals have a high degree of immunity to electromagnetic (EM) and radio frequency (RF) interference, thin, non-shielded cable can be used to route them.

#### 3.1 Clock Signal Recommendations

The AKU230 has been specially designed to withstand the common problem of clock overshoot in digital systems, however Akustica always recommends that laptop audio systems use proper digital line termination.

The overall performance of digital systems relies on the use of proper termination techniques for the clock signal. This is particularly true in laptop platforms with integrated microphone modules where the digital microphone signals (clock and data) often run over long cable lengths (12-20 inches, 30-50cm). Without termination, transmission line properties can result in undesired effects such as clock overshoot and ringing, as shown in Figure 6 below, which can lead to increased EMI in the platform, increased power consumption of the overall audio system, and the potential for an increase in bit error rate.

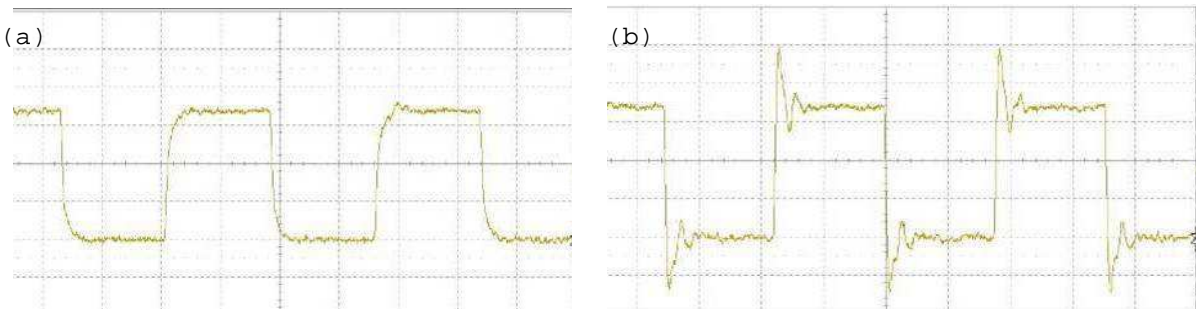

**Figure 6:** Comparison of (a) clean clock signal with proper terminations and (b) clock signal without proper terminations resulting in clock overshoot and ringing

The optimum solution to eliminate clock overshoot and ringing is to place a series resistor near the codec's clock output. The value of the series resistor should be between  $100\Omega$ - $250\Omega$  depending on codec clock's drive strength and the type and length of the cable used to run the clock from the motherboard to the digital microphone module. The optimum resistor value for any platform will eliminate overshoot but will not cause timing related errors or compromise performance.

If the motherboard-side termination technique is not used, termination on the microphone module can also be accomplished by placing a series resistor on the clock line. Reducing the overshoot at the microphone generally requires a larger resistor value than one placed near the codec's clock output, so values of 200-600Ω or more are more common. Depending on cable length, clock signal strength, and other factors, adjust the resistor value to eliminate overshoot while maintaining a valid clock signal. Probing the clock signal between the series resistor and the microphone, as close to the microphone as possible, will allow one to properly assess the signal quality.

### 3.2 Reference Module Schematic

Akustica has designed a sample microphone module circuit for reference. The schematic is shown in Figure 7 and the recommended component values are shown in Table 2.

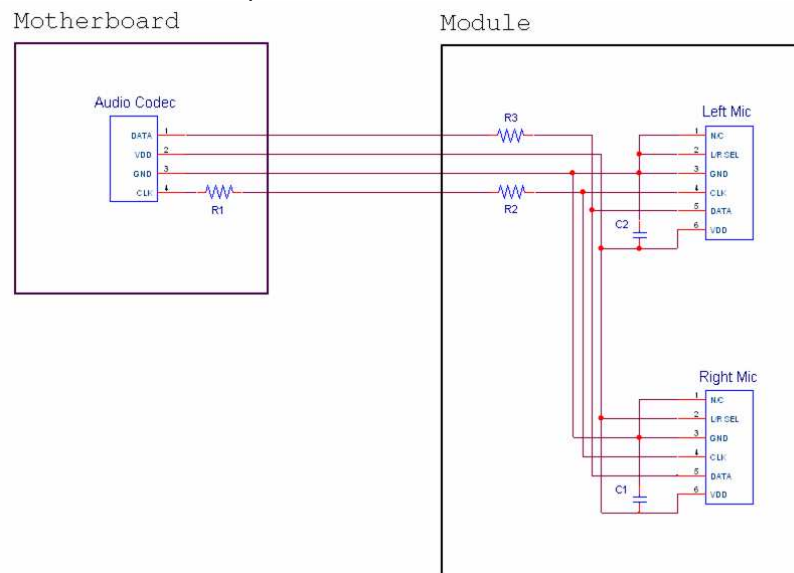

**Figure 7:** Electrical Schematic for Connecting a Digital Microphone Array.

	<b>AKU230</b> Microphone Module Design Guide	Application Note
-----------------------------------------------------------------------------------	-------------------------------------------------	------------------

### 3.2 Reference Module Schematic (cont.)

Component	Function	Suggested Value	Location	Notes
R1	Clock termination resistor: prevent clock overshoot and ringing	100-250Ω	On motherboard near clock output from codec	Should always be included.
R2	Clock termination if R1 not present on motherboard	0Ω or 200Ω -600Ω	On microphone module's clock line	Include resistor place holder on module in all cases. Populate with a 0Ω short if the motherboard already includes proper CLK line series resistor (R1).
R3	Mic data termination: prevent overshoot and ringing.	0Ω - 50Ω	On module's DATA line.	Only necessary if cabling causes overshoot or ringing on dataline at input to audio codec.
C1, C2	Decoupling capacitor: suppress high frequency transients and ensure good system ESD performance.	0.1 μF	Close to the V <sub>DD</sub> pin between V <sub>DD</sub> and GND	Keep traces as short as possible

**Table 2:** Summary of reference design components for integrated camera module

Additional electrical design recommendations should be noted:

- Configure the AKU230 to be a left or right microphone by setting Pin 2 (L/R SELECT) to either GND (left) or V<sub>DD</sub> (right).
- Audio codec configuration should determine L/R microphone selection for mono microphone applications. If the codec is configurable for mono microphones, then Akustica recommends configuring the AKU230 as a right (R) microphone.
- In general, route GND next to CLK. This is done to provide a closely coupled ground return for the clock currents and to isolate the clock from the other signals, preventing cross-talk.

	<b>AKU230</b> Microphone Module Design Guide	Application Note
-----------------------------------------------------------------------------------	-------------------------------------------------	------------------

## 4. ACOUSTIC DESIGN

### 4.1 Gasket Recommendations

The acoustic port of the AKU230 microphone is in the top of the package. An acoustic seal is highly recommended between the acoustic port on the device and the front plastic casing of the bezel. Such a seal can be accomplished using a gasket. The airtight seal between the microphone and the bezel maximizes the strength of the acoustic signal to the microphone and prevents acoustic signals in the interior of the PC from leaking to the microphone or undesired resonances caused by the cavity of the bezel.

The gasket material should provide the optimal combination of compliance and mechanical damping to decouple the microphone from bezel vibrations. The gasket material should also be robust to environmental conditions; for example, it should maintain the airtight seal during and after temperature and humidity testing. Such a material can be rubber, neoprene, or foam. Alternatively, a molded rubber boot can be used instead of a gasket if space allows. A mesh covering should be added to the front of the bezel port to provide environmental protection from dust and other particulates. The mesh must be acoustically transparent to minimize the impact on the performance of the microphone array.

### 4.2 Acoustic Port Recommendations

The acoustic port of the laptop plastics and the gasket should be at least 1.0 mm in diameter and should be aligned with the port in the microphone package. In the case of a noncircular port, the minimum bezel port dimension should be big enough that the acoustic port of the AKU230 is not obstructed by the gasket or bezel in order to ensure the highest acoustic fidelity. To resolve alignment issues and prevent obstruction of the microphone port, use an oversized hole whose diameter accounts for assembly tolerance. Additional vibration absorbing material can also be used to mechanically isolate the PCB onto which the microphone is mounted from the bezel plastic to prevent vibrations from being absorbed by the microphone.

	<b>AKU230</b> Microphone Module Design Guide	Application Note
-----------------------------------------------------------------------------------	-------------------------------------------------	------------------

### 4.3 Mechanical Design Recommendations

Figure 8 shows a side view of a typical mechanical interface to the AKU230. The design of the acoustic port should ensure that the AKU230 port hole is not obstructed. Additionally, the design should minimize height, H, and maximize diameter, D (a good minimum target ratio for D:H is 1:2).

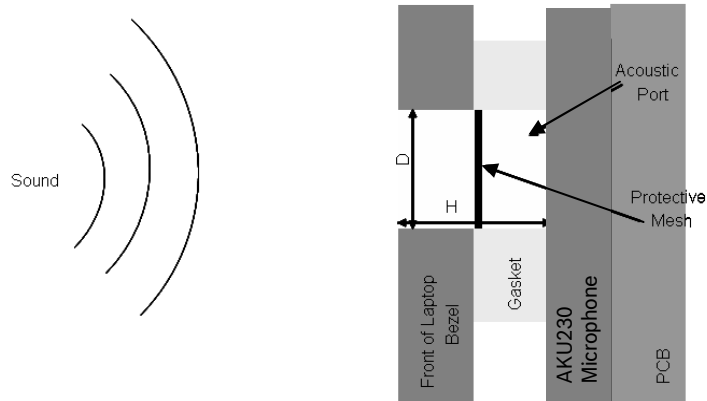

**Figure 8:** Cross-sectional view of the recommended acoustic porting solution for the AKU230 showing diameter (D) and height (H) of the acoustic port.

These suggestions will help to further prevent unwanted resonances from forming in the system. The frequency and magnitude of these resonances will also depend on the overall shape of the acoustic port cavity. Since it may be difficult to achieve a minimum port height in a camera module design due to the height of the camera itself, Akustica can help the laptop manufacturer by modeling proposed acoustic porting solutions to minimize undesirable resonances.

	<b>AKU230</b> Microphone Module Design Guide	Application Note
-----------------------------------------------------------------------------------	-------------------------------------------------	------------------

## 5. DEVICE HANDLING RECOMMENDATIONS

### 5.1 ESD and CMOS devices

Due to the monolithic CMOS nature of the AKU230, standard CMOS handling and application precautions apply. As with any CMOS device, the AKU230 is composed of complementary pairs of P-channel and N-channel metal oxide semiconductor field effect transistors (MOSFETs). Because of this, CMOS devices present very high input impedances, which make CMOS devices sensitive to charge build-up and electrostatic discharge (ESD). An electrostatic discharge may damage a CMOS device, or impair its reliability.

The AKU230 includes built-in ESD protection circuits to protect against discharge levels of up to 2,000V for a human body model of ESD, and 200V for a machine model of ESD. However, observe proper handling of CMOS devices at all times in order to avoid possible high static voltage conditions.

Basic CMOS handling procedures include:

- 1) Use of insulating foam or ESD-safe containers and bags for transportation.
- 2) Use of grounded wrist straps and grounded ESD mats.
- 3) Use of grounded manufacturing, test and evaluation equipment.
- 4) Use of grounded manufacturing floors.
- 5) Devices should not be "hot" inserted or removed.

Other methods to reduce charge build-up, such as ESD clothing and localized air ionization, may be also be used. For a more detailed description of ESD control methods, the ESD Association may provide additional information:

[http://www.esda.org/esd\\_fundamentals.html](http://www.esda.org/esd_fundamentals.html)

	<b>AKU230</b> Microphone Module Design Guide	Application Note
-----------------------------------------------------------------------------------	-------------------------------------------------	------------------

## 5.2 Pickup Tool Pick Location

As with any MEMS device, care needs to be taken to avoid damaging the part's micro-machined structures. In MEMS microphones an acoustic port connects the outside air to the membrane inside the device. Because of this, pick-and-place vacuum nozzles should avoid placing suction on the acoustic port of the microphone. Akustica recommends placing the vacuum nozzle's port at least 1 mm off center of the part, away from the microphone's acoustic port as shown below in Figure 9.

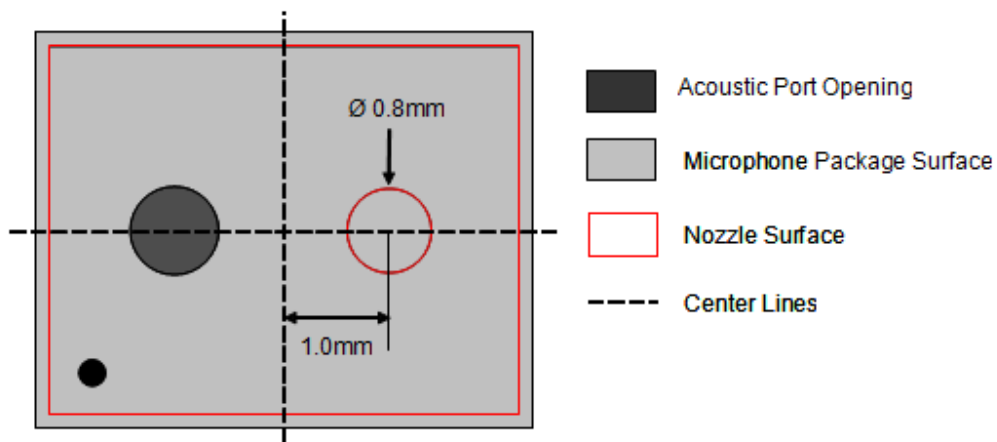

*Figure 9: Recommended vacuum nozzle design.*

## 6. CONCLUSION

The mechanical and electrical guidelines provided in this document will enable the optimum acoustic performance for any embedded microphone module (with or without cameras) that will be placed in the monitor bezel of a notebook PC such as the module. For additional information or design recommendations and review, please contact Akustica directly.

Akustica, Inc.  
A Subsidiary of the Bosch Group  
2835 East Carson Street  
Suite 301  
Pittsburgh, PA 15203  
Ph: (412) 390-1730  
For technical support contact [support@akustica.com](mailto:support@akustica.com)  
[www.akustica.com](http://www.akustica.com)