

May 2010

AKU2002CH Microphone Module Design Guide

INTRODUCTION

This document provides complete mechanical and electrical guidelines for the design of an embedded microphone module (with or without cameras), shown in Figure 1, that will be used in laptop PC's, monitors, tablets or other module applications. All electromechanical recommendations in this guide will also apply to any design using the AKU2002CH and can be applied to any form factor. The first two sections discuss the types of embedded microphone modules and the recommended location for the module. The last two sections present electrical layout guidelines and mechanical/plastics recommendations for optimum acoustic performance and ESD protection of the microphone module.



Figure 1: Audio/video module with dual digital microphones

A quick summary of the electrical and mechanical guidelines for designing the highest quality audio module is shown in Table 1. All recommendations are covered in greater detail on the page number indicated.

Microphone Module Location (Page 3)	<ul style="list-style-type: none"> • Top of the display bezel in the laptop PC or desktop monitor.
Electrical Design Recommendations for Motherboard Manufacturer (Page 4)	<ul style="list-style-type: none"> • A series resistor of 100Ω-250Ω or higher should be placed on the CLK line close to the codec output on the motherboard to terminate the clock line to prevent clock overshoot and ringing.
Electrical Design Recommendations for Microphone Module Manufacturer (Page 5)	<ul style="list-style-type: none"> • A 0.1 μF decoupling capacitor should be placed between V_{DD} and GND as close to the microphone as possible (for each microphone on the module) in order to suppress high frequency transients and decrease susceptibility to ESD events. • If CLK line has not been terminated on the motherboard, a larger series resistor of 200Ω-600Ω or higher must be placed on the CLK line of the module to prevent clock overshoot and ringing as seen by the part. • GND line should be routed next to CLK line.
Mechanical Design Recommendations (Page 6)	<ul style="list-style-type: none"> • The design of the acoustic port should minimize port height (H) and maximize port diameter (D), while maintaining an airtight seal between the gasket and the microphone.

Table 1: Summary of design recommendations for integrated camera modules in laptops

Application Note: AKU2002CH Microphone Module Design Guide

TYPES OF INTEGRATED MICROPHONE MODULES

There are two main types of microphone modules for laptop PCs and desktop monitors:

- Microphone modules which output audio to the HD Audio CODEC on the motherboard. This is the type most likely to be used in a laptop PC.
- Microphone modules which output audio to an on-board audio/video controller which ultimately outputs USB audio and video. This is the type most likely to be used in a desktop monitor or external webcam.

In the first type of the module, either the mono or the stereo (multiplexed) single-bitstream output of the AKU2002CH microphones is routed directly from the module to the HD Audio CODEC that is located on the motherboard of the laptop. Because the output of the AKU2002CH is digital and therefore has a high degree of immunity to RFI/EMI (radio frequency and electromagnetic interference), it is not necessary to use shielded cabling when routing this signal down the side of the bezel, through the hinge, and to the motherboard.

These modules also often include a camera whose output goes directly into the video controller located on the module which generates video in USB format. The block diagram of this type of microphone module is shown in Figure 2.

In this implementation, the video output of the camera module is in the USB format, while the audio output of the camera module is the multiplexed single bitstream output from the microphones.

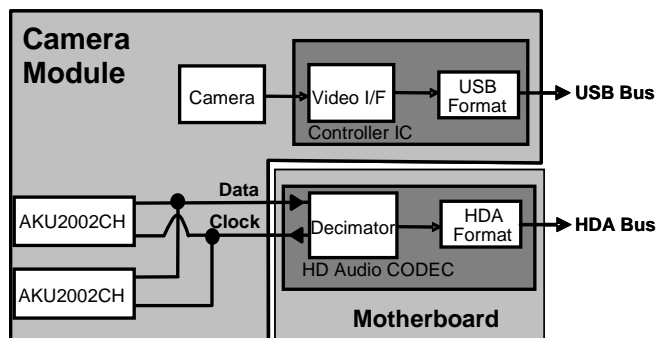

Figure 2: Block diagram of one type of camera module with an integrated digital microphone array.

The second type of microphone module is shown in Figure 3. In this implementation, the module also includes a camera and the on-module audio/video controller has been designed to directly interface with digital microphones. In this case, both the audio and the video output from the camera module are in USB format. This camera module solution is the most simple to integrate as it has the least number of wires running from the camera module, through the hinge, and to the motherboard.

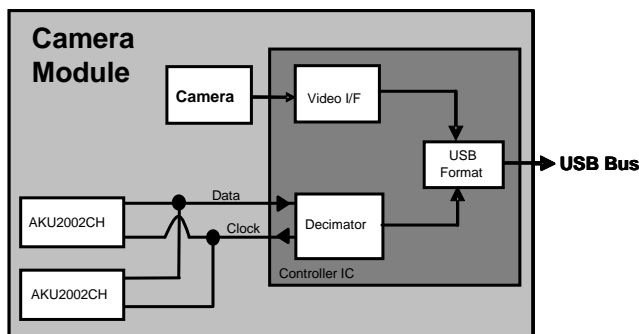

Figure 3: A second method for developing a camera module with an integrated digital microphone array in which both the audio and the video outputs from the camera module are in the USB format.

Application Note: AKU2002CH Microphone Module Design Guide

TYPES OF INTEGRATED MICROPHONE MODULES (cont.)

For any microphone module using two or more microphones, the spacing of the microphones will be determined by the particular microphone array software used in the platform since these algorithms are typically optimized for specific distances between microphones in the array. It is recommended that designers also follow the guidelines outlined in the Microsoft white paper entitled "Microphone Array Support in Windows Vista" which can be found at <http://www.microsoft.com/whdc/device/audio/micarrays.msp>.

MICROPHONE MODULE LOCATION

The typical location for a camera module is in the top of the display bezel in the laptop PC. The following section discusses why this is also the ideal location for a microphone array and therefore also for the integrated audio/video camera module.

The positioning of an integrated microphone array should be selected both to maximize the audio signal and to minimize external noise experienced at the microphone, thereby improving the overall SNR (signal-to-noise ratio). It is recommended that to maximize the SNR of the audio signal and take full advantage of the microphone array signal processing, microphones should be embedded in the display bezel, facing the talker. This provides the most direct path from mouth to microphone, enabling optimum talker tracking and ambient noise suppression.

To minimize mechanical noise interference on the microphone array, place the microphones as far as possible from internal laptop noise sources such as the fan, speaker, and keyboard which are typically located in the laptop base. The sound pressure level reaching the microphones from each of these sound sources will be reduced by 6 dB when the distance between the microphone and the noise source is doubled. Therefore, minimal noise interference will be experienced by the array if it is removed from the base and is placed at the farthest possible point away from noise sources.

Consequently, one can both increase signal and decrease internal laptop noise by placing the microphone array (or the integrated audio/video camera module) in the top bezel of the laptop display as shown in Figure 4.

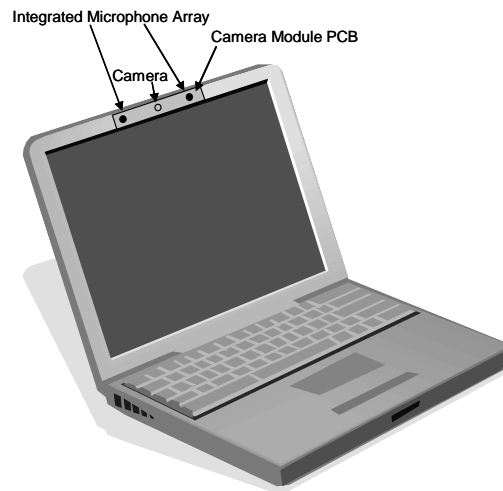

Figure 4: Ideal location for camera module with integrated microphone array

Application Note: AKU2002CH Microphone Module Design Guide

ELECTRICAL DESIGN

There are several options for integrating the surface-mountable AKU2002CH into the bezel of a notebook PC. One solution is to surface-mount the microphones individually to small boards in the bezel and connect a 4-wire harness (power, ground, clock, and data) to each microphone. If taking advantage of the multiplexing capabilities of the AKU2002CH, the data lines can then be tied together as they are routed to the CODEC. Alternatively, the microphones can be directly mounted to a board that already exists in the display bezel such as those with internal camera modules.

Another solution is to use a thin flex cable extending from the microphone to the CODEC. The flex cable is convenient in that it is easy to design very thin; however, flex cables may not provide the most cost-effective solution for mounting a microphone array in a laptop. Thin, non-shielded cable can be used to route the AKU2002CH signals since they have a high degree of immunity to electromagnetic (EM) and radio frequency (RF) interference.

Clock Signal Recommendations

The overall performance of digital systems such as this relies on the use of proper termination techniques for the clock signal. This is particularly true in laptop platforms with integrated microphone modules where the digital microphone signals (clock and data) often run over long cable lengths (12-20 inches). Without termination, transmission line properties can result in undesired effects such as clock overshoot and ringing, as shown in Figure 5 below, which can lead to increased EMI in the platform, increased power consumption of the overall audio system, decreased sensitivity, and the potential for an increase in bit error rate. Therefore, attention should be paid in laptop designs to ensure that proper digital line terminations are employed.

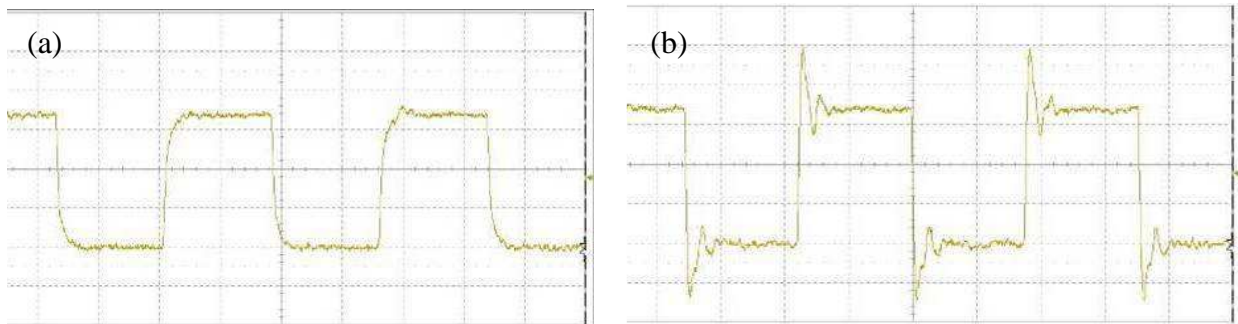

Figure 5: Comparison of (a) clean clock signal with proper terminations and (b) clock signal without proper terminations resulting in clock overshoot and ringing

The optimum solution to eliminate clock overshoot and ringing is to place a series resistor at the output of the clock on the motherboard. The value of the series resistor should be between 100Ω-250Ω depending on the specific type and length of the cable used to run the clock from the motherboard to the digital microphone module. The optimum resistor value for any platform will eliminate overshoot but will not cause timing related errors or compromise performance.

If the motherboard-side termination technique is not used, termination on the microphone module can also be accomplished by placing a series resistor on the clock line. Reducing the overshoot at the microphone generally requires a larger resistor value than one placed near the codec's clock output, so values of 200-600Ω or more are more common. Depending on cable length, clock signal strength and other factors, adjust the resistor value to ensure overshoot has been eliminated while maintaining a valid clock signal. Probing the clock signal between the series resistor and the microphone, as close to the microphone as possible, will allow one to properly assess the signal quality.

Application Note: AKU2002CH Microphone Module Design Guide

ELECTRICAL DESIGN (CONT.)

Reference Module Schematic

Akustica has designed a sample microphone module circuit for reference. The schematic is shown in Figure 6 and the recommended component values are shown in Table 2.

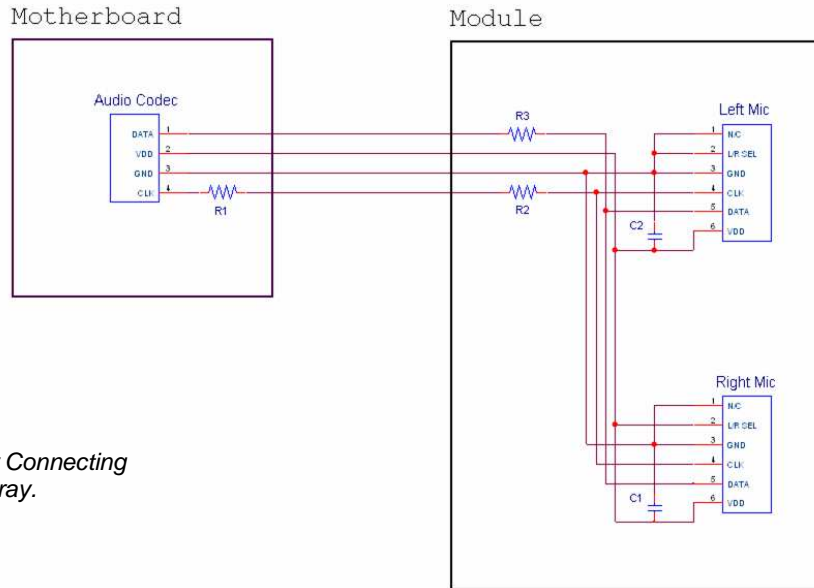

Figure 6:
Electrical Schematic for Connecting a Digital Microphone Array.

Component	Function	Suggested Value	Location	Effects of missing component	Notes
R1	Clock termination resistor: prevent clock overshoot and ringing	100-250Ω	On motherboard near clock output from CODEC	Reduced microphone sensitivity	Should always be included.
R2	Clock termination if R1 not present on motherboard	0Ω or 200Ω -600Ω	On microphone module's clock line	Reduced microphone sensitivity	Include resistor place holder on module in all cases. Populate with a 0Ω short if the motherboard already includes proper CLK line series resistor (R1).
R3	Mic data termination: prevent overshoot and ringing.	0Ω or 47Ω	On module's DATA line.	Digital signal degradation and reduction of audio quality	Only necessary if cabling causes overshoot or ringing on dataline at input to audio codec.
C1, C2	Decoupling capacitor: suppress high frequency transients and ensure good system ESD performance.	0.1 μF	Close to the V _{DD} pin between V _{DD} and GND	Reduced ESD protection, reduction of audio quality.	Keep traces as short as possible

Table 2: Summary of reference design components for integrated camera module

Application Note: AKU2002CH Microphone Module Design Guide

ELECTRICAL DESIGN (CONT.)

Reference Module Schematic (Cont.)

Additional electrical design recommendations should be noted:

- Configure the AKU2002CH to be a left or right microphone by setting Pin 2 (L/R SELECT) to either GND (left) or V_{DD} (right).
- Audio CODEC configuration should determine L/R microphone selection for mono microphone applications. If the CODEC is configurable for mono microphones, then Akustica recommends configuring the AKU2002CH as a right (R) microphone.
- In general, route GND next to CLK. This is done to provide a closely coupled ground return for the clock currents and to isolate the clock from the other signals, preventing cross-talk.

ACOUSTIC DESIGN

Gasket Recommendations

The acoustic port of the AKU2002CH microphone is in the top of the package. An acoustic seal is needed between the acoustic port on the device and the front plastic casing of the bezel. Such a seal can be accomplished using a gasket. The airtight seal between the microphone and the bezel maximizes the strength of the acoustic signal to the microphone and prevents acoustic signals in the interior of the PC from leaking to the microphone or undesired resonances caused by the cavity of the bezel.

The gasket material should provide the optimal combination of compliance and mechanical damping to decouple the microphone from bezel vibrations. The gasket material should also be robust to environmental conditions; for example, it should maintain the airtight seal during and after temperature and humidity testing. Such a material can be rubber, neoprene, or foam. Alternatively, a molded rubber boot can be used instead of a gasket if space allows. A mesh covering should be added to the front of the bezel port to provide environmental protection from dust and other particulates. The mesh must be acoustically transparent to minimize the impact on the performance of the microphone array.

Acoustic Port Recommendations

The acoustic port of the laptop plastics and the gasket should be at least 1.0 mm in diameter and should be aligned with the port in the microphone package. In the case of a noncircular port, the minimum bezel port dimension should be big enough that the acoustic port of the AKU2002CH is not obstructed by the gasket or bezel in order to ensure the highest acoustic fidelity. To resolve alignment issues and prevent obstruction of the microphone port, use an oversized hole whose diameter accounts for assembly tolerance. Additional vibration absorbing material can also be used to mechanically isolate the PCB onto which the microphone is mounted from the bezel plastic to prevent vibrations from being absorbed by the microphone.

Application Note: AKU2002CH Microphone Module Design Guide

Mechanical Design Recommendations

Figure 7 shows a side view of a typical mechanical interface to the AKU2002CH. The design of the acoustic port should ensure that the AKU2002CH port hole is not obstructed. Additionally, the design should minimize height, H , and maximize diameter, D (a good minimum target ratio for $D:H$ is 1:2).

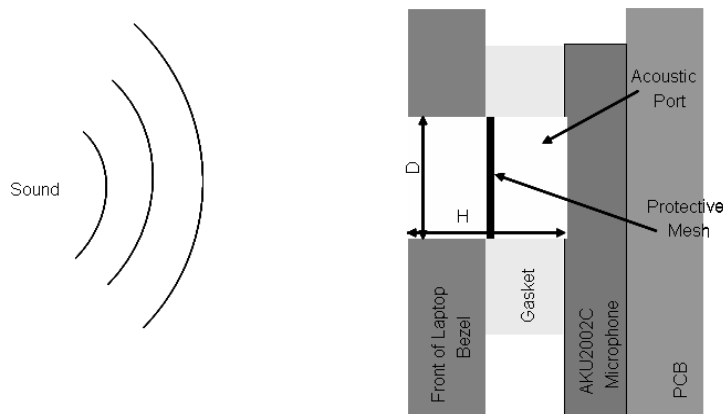

Figure 7: Cross-sectional view of the recommended acoustic porting solution for the AKU2002CH showing diameter (D) and height (H) of the acoustic port.

These suggestions will help to further prevent unwanted resonances from forming in the system. The frequency and magnitude of these resonances will also depend on the overall shape of the acoustic port cavity. Figure 8 shows the differences in the resonant frequencies when a gasket and housing are added to the microphone. Since it may be difficult to achieve a minimum port height in a camera module design due to the height of the camera itself, Akustica can help the laptop manufacturer by modeling proposed acoustic porting solutions to make sure that undesirable resonances will be minimized.

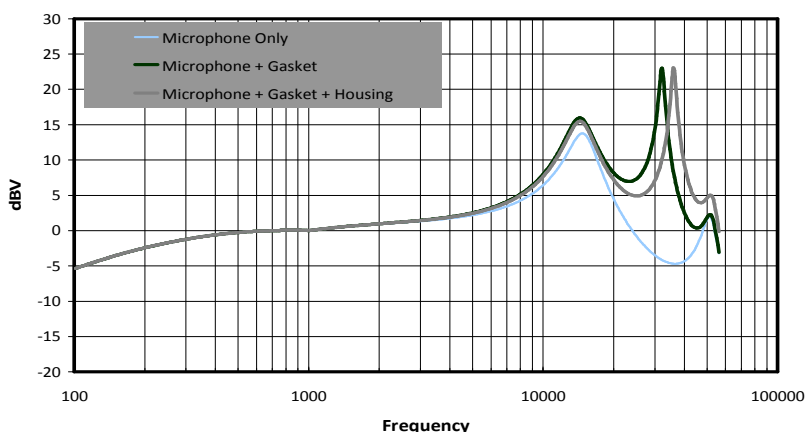

Figure 8: Example of how gasket and housing design impact microphone resonant frequency

Application Note: AKU2002CH Microphone Module Design Guide

CONCLUSION

The mechanical and electrical guidelines provided in this document will enable the optimum acoustic performance for any embedded microphone module (with or without cameras) that will be placed in the monitor bezel of a notebook PC such as the module. For additional information or design recommendations and review, please contact Akustica directly.

Akustica products are sold by description only. Akustica reserves the right to make changes in circuit design, software and/or specifications at any time without notice. Accordingly, the reader is cautioned to verify that data sheets are current before placing orders. Information furnished by Akustica is believed to be accurate and reliable. However, no responsibility is assumed by Akustica or its subsidiaries for its use; nor for any infringements of patents or other rights of third parties which may result from its use. No license is granted by implication or otherwise under any patent or patent rights of Akustica or its subsidiaries.



Akustica, Inc.
A Subsidiary of the Bosch Group
2835 East Carson Street
Suite 301
Pittsburgh, PA 15203
Ph: (412) 390-1730
For technical support contact support@akustica.com
www.akustica.com